

HZS200M-39

MONOCRYSTALLINE SOLAR MODULE

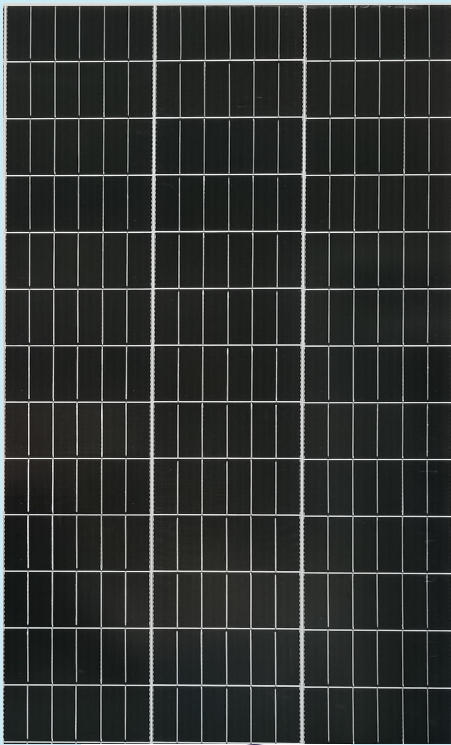

Trust Hangzhou Solar photoelectricity to Deliver Reliable Performance Over Time



Reliable IP67 Rated Junction Box

Industry-leading Warranty based on nominal power

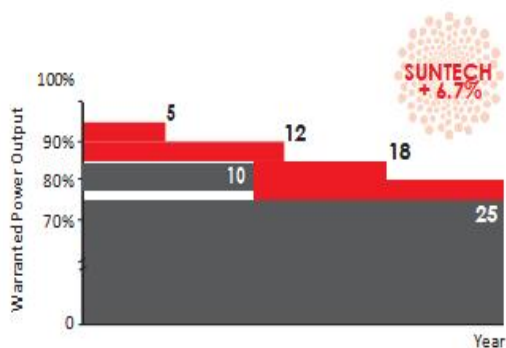

Feature



Hangzhou Solar current sorting process

System output maximized by reducing mismatch losses upto 2% with modules sorted & packaged by amperage



High module conversion efficiency

Module efficiency up to 19.87% achieved through advanced cell technology and manufacturing capabilities



Self-cleaning & anti-reflective

Higher module efficiency from anti-reflective, hydrophobic layer with higher light absorption and minimal surface dust



Excellent weak light performance

Excellent performance under low light conditions



Extended wind and snow load tests

Module certified to withstand extreme wind (3800 Pascal) and snow loads (5400 Pascal)



Positive tolerance

Guaranteed positive tolerance of up to 5% delivers higher outputs reliably



Maximize customer benefits

Maximize the benefits of end customers



Strict quality control

Very strict quality control process and introduction of lean production mode



Engineering drawings.

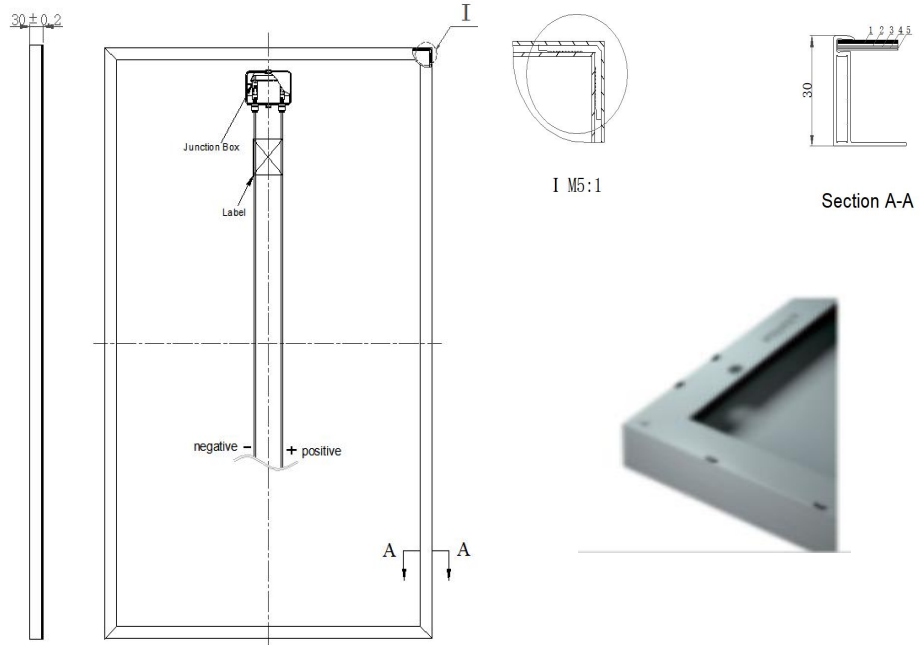
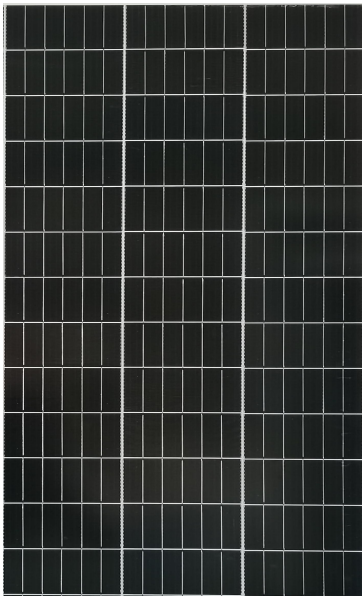

Mechanical Characteristics

Solar Cell	Monocrystalline silicon 210× 105mm
No. of Cells	39 (3 × 13)
Dimensions	1480 ×680 × 30mm
Weight	11kg
Front Glass	3.2 mm tempered glass
Frame	Anodized aluminium alloy

Temperature Characteristics

Nominal Operating Cell Temperature	45±2°C
Temperature Coefficient of Pmax	-0.40 %/°C
Temperature Coefficient of Voc	-0.31 %/°C
Temperature Coefficient of Isc	0.051 %/°C

I-V Curves of pv module

Current-Voltage Curve

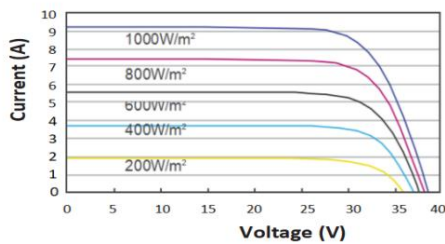

Power-Voltage Curve

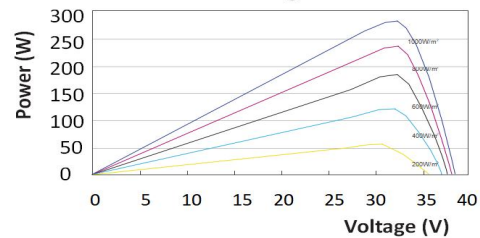

Electrical Characteristics

STC	HZS200M-39
Maximum Power at STC (Pmax)	200W
Optimum Operating Voltage (Vmp)	19.6V
Optimum Operating Current (Imp)	10.21A
Open Circuit Voltage (Voc)	23.52V
Short Circuit Current (Isc)	10.92A
Module Efficiency	19.87%
Operating Module Temperature	-40 °C to +85 °C
Maximum System Voltage	1500 V DC (IEC)
Power Tolerance	0/+5 %

STC: Irradiance 1000 W/m², module temperature 25 °C, AM=1.5;

